

PEL LED LML CP

CUST. 07/2021



GA Diagram:

Dimensions (in mm)

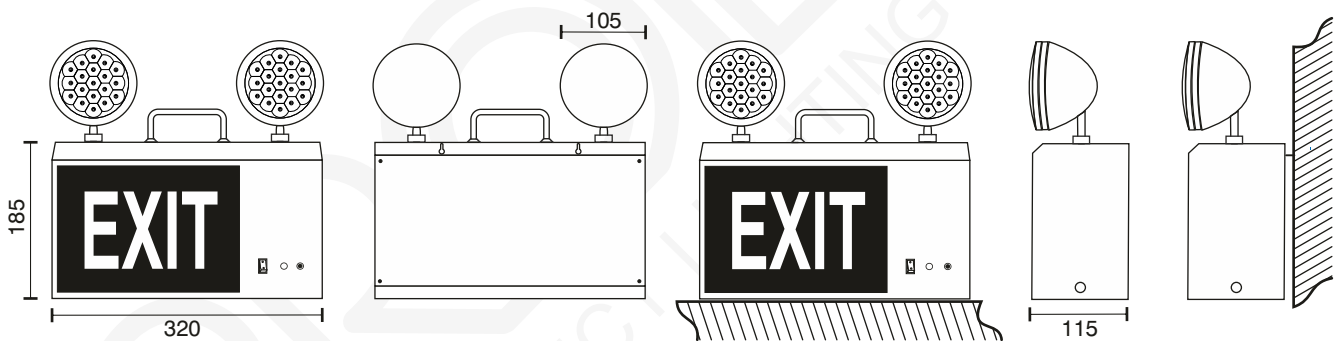

Non-Maintained , Exit-Maintained

Consist of twin LEDs lamps which, automatically switches – **ON**, on mains power failure & provides illumination on battery source for specified duration, after which the battery gets automatically cut-off, to facilitate quick recharge on the resumption of mains supply. Once the battery is fully charged, it automatically slides into trickle charge to constantly retain the charge and be ready for immediate use.

Tolerance on overall dimensions is ± 5 mm unless otherwise specified. | Please Note: Other Input Voltage Is Also Available – Price On Request (POR). | Due to continuous development, specifications may change without prior notice.

Technical Specifications

CONFORMS TO		IS - 10322
INGRESS PROTECTION		IP 20
HOUSING		22 MS C.R.C.A. FABRICATED
PAINT & COLOUR		EPOXY POLYESTER POWDER COATING, WHITE IN COLOUR.
DIFFUSER		CLEAR MOLDED ABS/ POLYCARBONATE.
REFLECTOR		CHROME PLATED.
LED		MULTIPLE LEDs, 2 X 3 WATT
LED MAKE		GMR LIGHT, BRIDGELUX, EDISON , OSRAM .
DIFFUSER OF EXIT		2 M. M. RED ACRYLIC, WITH CAD DESIGNED & VINYL CUT.
INPUT		~230 VOLTS, 50 HZ; $\pm 10\%$
MAINS CONNECTOR		5 A, 250 VOLTS MILKY WHITE POLYCARBONATE WITH ELECTRICAL GRADE
BATTERY		SMF RECHARGEABLE
DURATION		2 X 3 WATT LED 180 MINUTES BACK UP $\pm 10\%$. LED EXIT : MAINTAINED TYPE, 6 HOURS BACK UP.
CHARGING TYPE		CONSTANT VOLTAGE CHARGER.
RECHARGING CYCLE		10 TO 12 HOURS RECHARGING PERIOD
MOUNTING TYPE		ON WALL THROUGH 2 NOS. OF KEY HOLES OR CAN BE USED ON TABLE/SHELF.
WEIGHT (KG)		3 KG APPROX
INDICATION		RED LED "ON" INDICATES CHARGING
APPLICATION		COMMERCIAL PURPOSE, CORRIDORS OF HOTELS, BATTERY ROOMS, STAIRCASES, UNDERGROUND PARKING.

Tolerance on overall dimensions is ± 5 mm unless otherwise specified. | Please Note: Other Input Voltage Is Also Available – Price On Request (POR). | Due to continuous development, specifications may change without prior notice.