

LED ML / FP

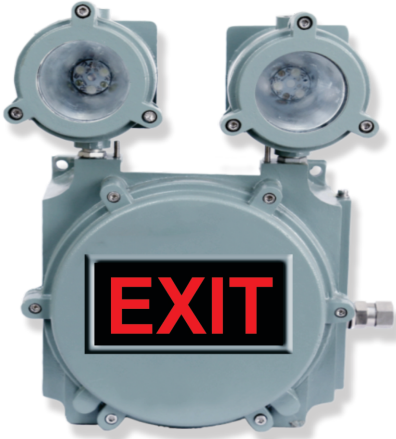

Features and Application

Flame Proof Multi Lights can be used indoors as well as outdoors; Autolite also has this product with an EXIT sign to serve as an 'EXIT' indicator in an emergency situation.

TECHNICAL DATA SHEET

Make	AUTOLITE
Confirms	IS 10322
Ingress Protection	IP 65
Housing	Cast Aluminum CMRI Certified Flame Proof Housing With Heat Resistant Clear Borosil Glass
Paint & Colour	Grey
Diffuser Come Message Panel	A CAD Designed, Vinyl Pasted Out Side The Heat Resistant Clear Borosil Glass Diffuser.
Input Voltage	230 Volts Supply
LED	2 x18 Watt Multiple LEDs.
Mains Cord	5 A, 250 Volts 3 Pin 2 Yard
Lamp Make	Osram, Philips, Everlite
Battery Type	12 Volt SLA Rechargeable Battery
Duration	3 Hrs. Back up
Charging Type	Constant Current Charger
Recharging Cycle	16 to 24 hrs. Recharging Period
Mounting	Surface Mounting
Weight	10 Kg. Approx
Application	Industrial Purpose, In Chemical & Hazardous Industries, where Ignition of Inflammable Material is Very Casual.

Dimensions (mm)

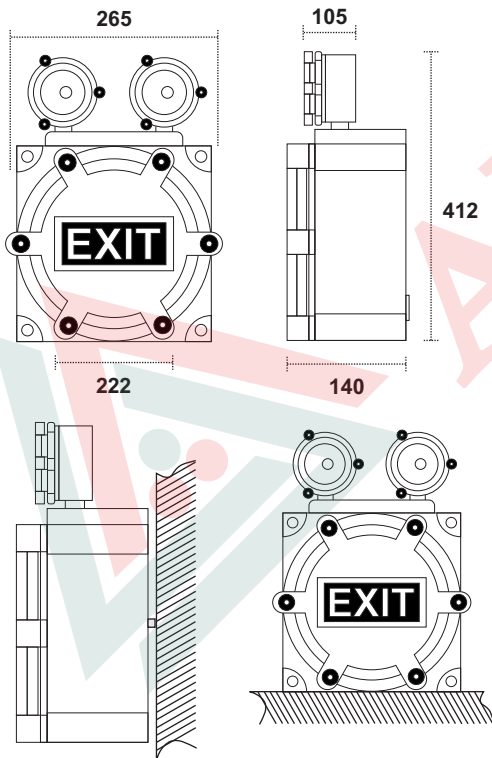

TECHNICAL DETAILS

- Type of protection & Gas Group :** Enclosure, Aluminium Alloy LM-6, Flame Proof (Explosion Proof)
Ex-d as per IS : 2148 / 1981 & IS : 13346 / 1992.
- Area Classification :** Zone 1 & 2, Gas Group IIA & IIB.

Specifications:- Subject to changes without prior notice.

EMERGENCY FLAME PROOF MULTI LIGHTS (IP 65)

Ordering Information

MODEL	LAMP
LED ML /FP	LED