

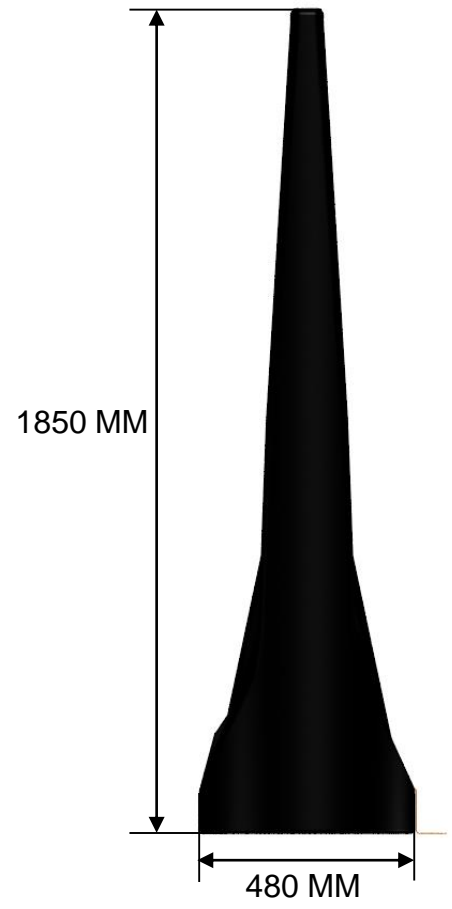

Metro Barricade Model - II

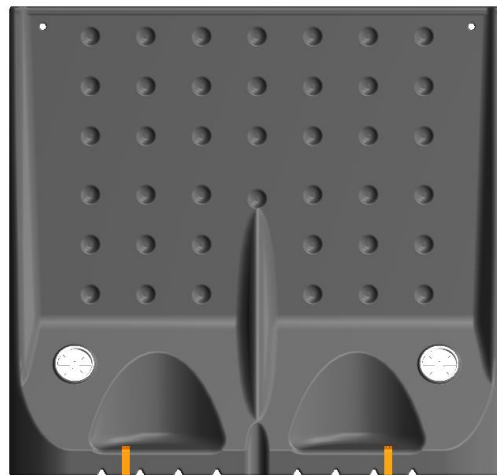



Metro Barricade Model II

- Material : High durable virgin premium grade Polyethylene material
- UV Stabilized
- Anti-static properties.
- Can withstand the high wind pressure.
- No rust, No chip, No peel.
- Completely maintenance free
- Provision for fixing retro-reflective sheet in an embossed position .
- Pasting retro reflective sheet helps prevent vandalism, and enhances high visibility during the night.
- The barricades have smooth rounded edges and corners at all places to avoid injury.
- 3 nos. of anchoring facility to the ground is given at the back for more sturdiness.
- holes at the upper corners for interlocking the barricade with the help of Ropes / wires etc. Also the anchoring facility to the ground is given at the back for more sturdiness.



Interlocking of Barriers creates an upright wall effect.

Front View



Back View

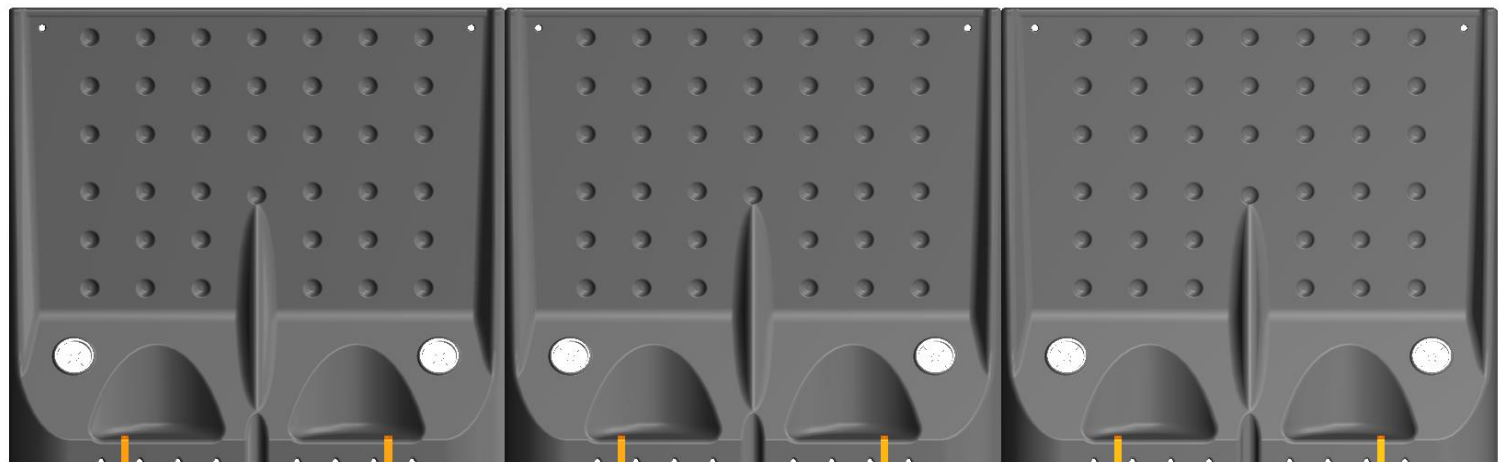



Interlocking of Barriers creates an upright wall effect.

Front View



Back View

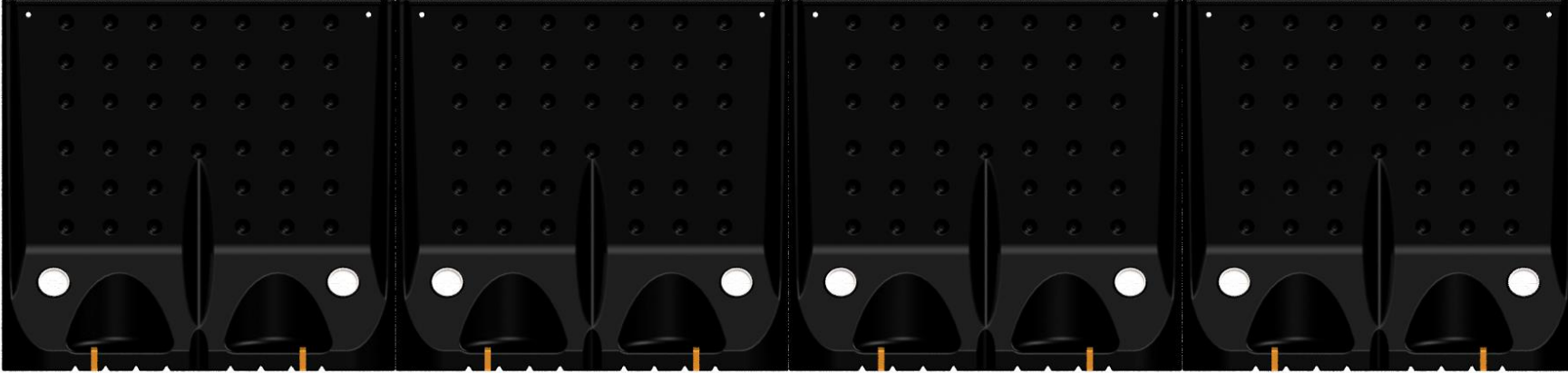

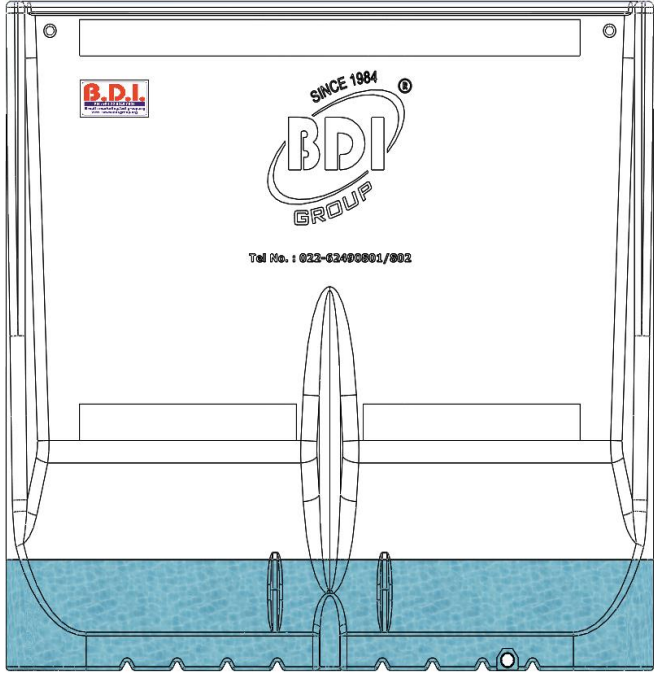

**WATER FILLABLE
CAPACITY 100 LTRS.**

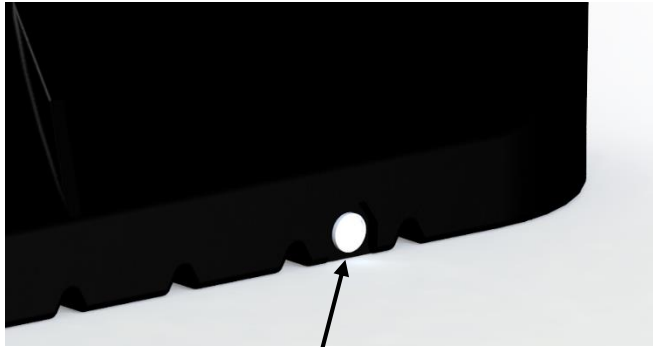
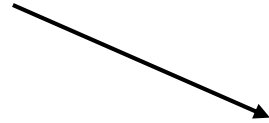

WATER OUTLET

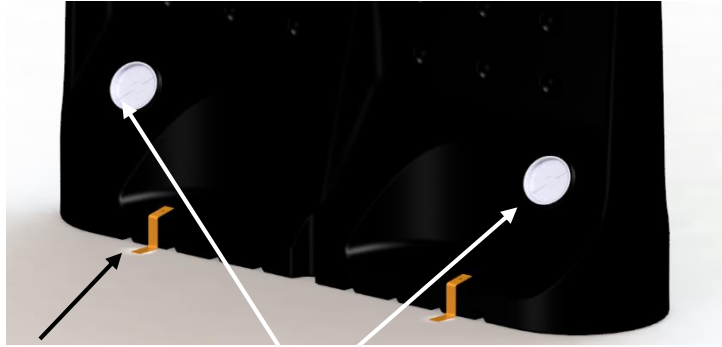

**GROUTING
PROVISION**

WATER INLET

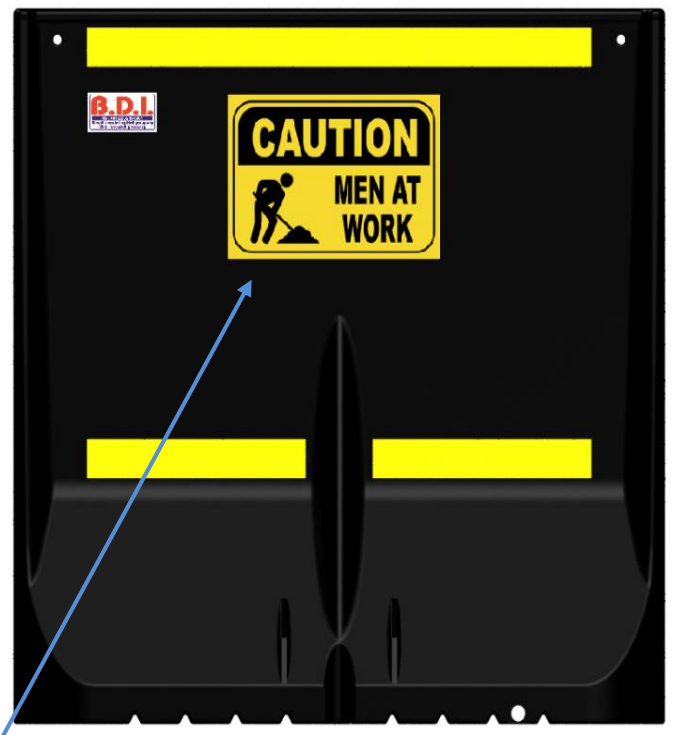
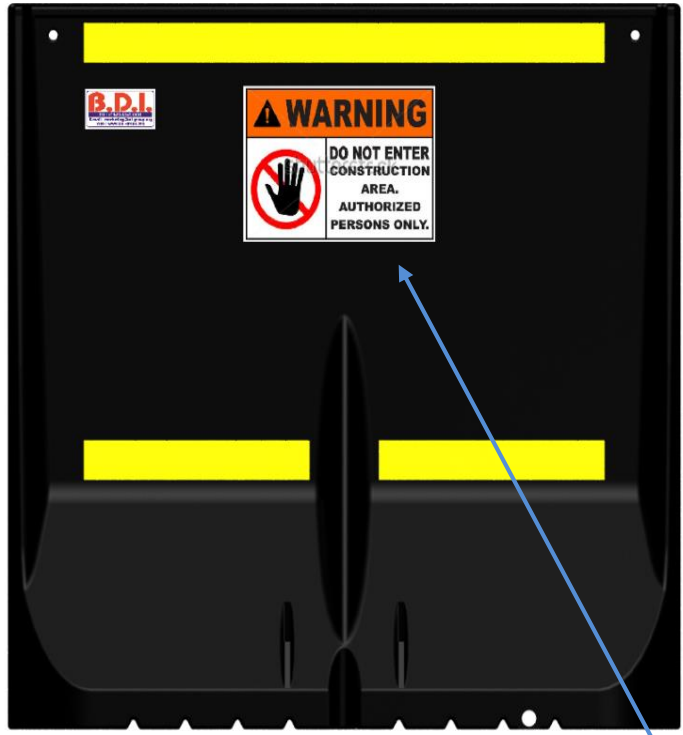

Space provided for message / sticker / logo

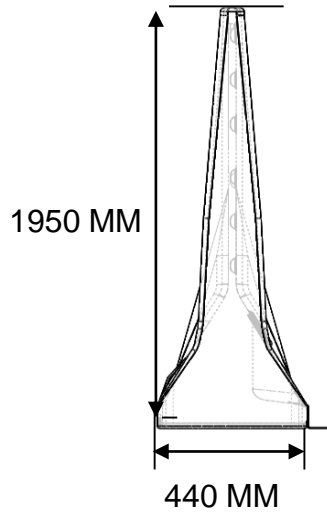
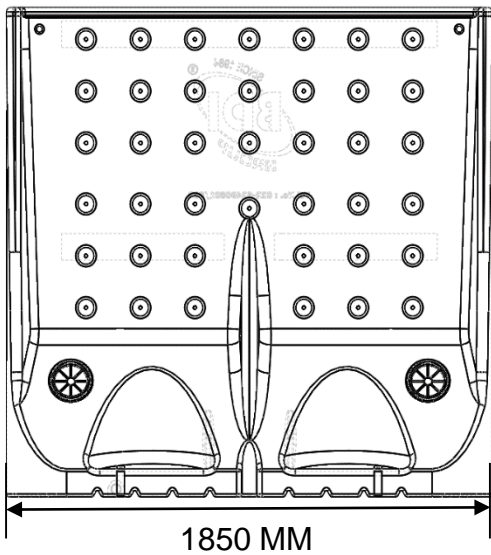

Length	1850mm*
Width	440mm*
Height	1950mm*
Water Ballast Minimum	100 Ltrs*
Non Fading Color	Yes
UV Stabilized	Yes
Interlinking Provision	Yes
Drain Plug	Yes
Retro Reflective Color	Yellow
Barrier Color Availability	Black
Sticker Pasting Slot	Available
Sticker Pasting Slot Size	1500mm x 500mm



THANK YOU