

ET05NW

SENSOR TAP

Basin Mount



WATER SAVING
TECHNOLOGY

KEY FEATURES

Operation	Automatic, Infra-Red Sensor
Water Pressure	1.5 L - 2.0 L / min
Sensing Range	09 - 20 cm
Power	Electrical (AC 220V, 50Hz) + Battery (4 x AA Duracell)

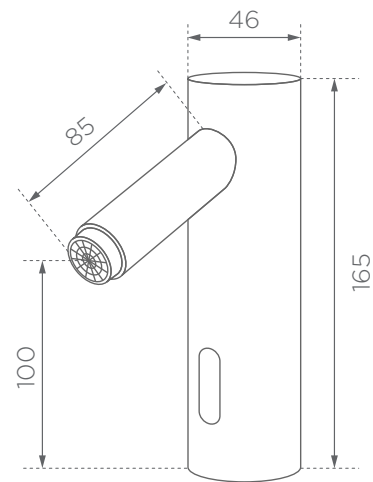

visit www.euronics.co.in
for a full range of euronics inspire products



All measurements are in mm.