

# X-ray Baggage scanner

TH5030A



Astrosonic Imaging Systems

## Product Highlight

- ARM cpu
- Digital signal and processor
- Continuous hard work for 10000 hours
- Energy saving design
- High penetration
- Good quality images

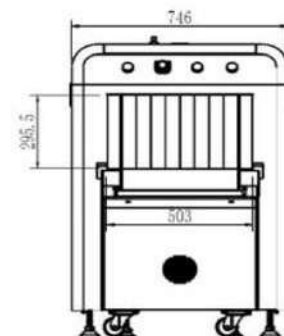
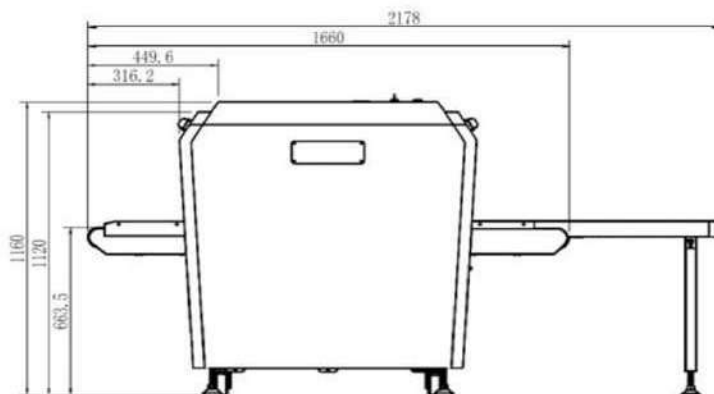

### Important Sizes :

Product Size: 1660\*746\*1160mm (L × W × H)

Tunnel Size: 500\*300mm (width × height)

# Product Detail



Unit weight	450kgs
Unit size	1350(L)*820(W)*1190(H) mm
Tunnel size(mm)	500(L)*300(W)
Conveyor Speed(m/s)	0.2
Conveyor height(mm)	663
Conveyor Max Load(kgs)	100
Penetration	Typical 12mm steel. guarantee 10 mm steel
Wire Resolution	Typical AWG40, guarantee AWG38
X-Ray Leakage	Less Than 0.1mR / hr
Power consumption	Max.0.8KVA
SIN ratio	<60dB
Film Safety	Guarantee ASAIIIS01600 Film

## Configuration

X-Ray generator	100 KV, oil cooling, from bottom to top
Computer	CPU: Cortex A9
Monitor	Dell or Acer, 17" LED screen, resolution 1280*1024 pixel
Operation System	Linux

## Software

Image Enhancement	1-64times enlargement continuity, Color/BW, negative,highlowpenetration, organic /inorganic Stripping, general enhancement, and pseudo color,etc.
Image Recall	All preceding images recallable,retrieval.
Image Archive	Up to 100,000 images stored automatically, enable transferring to USB disk, and converting to JPG, BMP, XF, PNG, TIFF, GIF six formats.
Other Functions	Time/date display, counters, user management, system-on/X-ray-on timers, power on self test, built-in diagnostic facilities, dual-direction scanning, system log, system standby and stimulant training, ADS etc.
Network Applications	Multiple remote applications available based on Ethernet LAN and windows platform, such as image centralized storage and identify, recheck workstation, and network TIP, etc (Optional).

## Operating Environment

Operation temperature/Humidity	0C-45C / 5%-95%(non-condensing)
Storage temperature/Humidity	-40C-70C I 5%-95%(non-condensing)
Operation Power	220VAC(±10%)50±3Hz

## MARKETED BY



**D.B. IMPEX**  
+91 8320383785  
+91 9998011004  
sales@dbimpex.in  
dbimpex.in



## Astrosonic Imaging Systems

Factory Address: GAT No-776, Pawarwasti, Kudalwadi, chikhali, Pune-412114  
Email id:info.astrosonic@gmail.com Mob No:7972559687