

ECO

AZSW108A 400

AZSW108B 800



Dear user:

Thank you for selecting of our intelligent remote control swing gate opener!
Please carefully read this Instruction Manual before installation and use. If you
have any problem that you can't settle during use, please contact your local
distributor of our products.

Structures & Classification

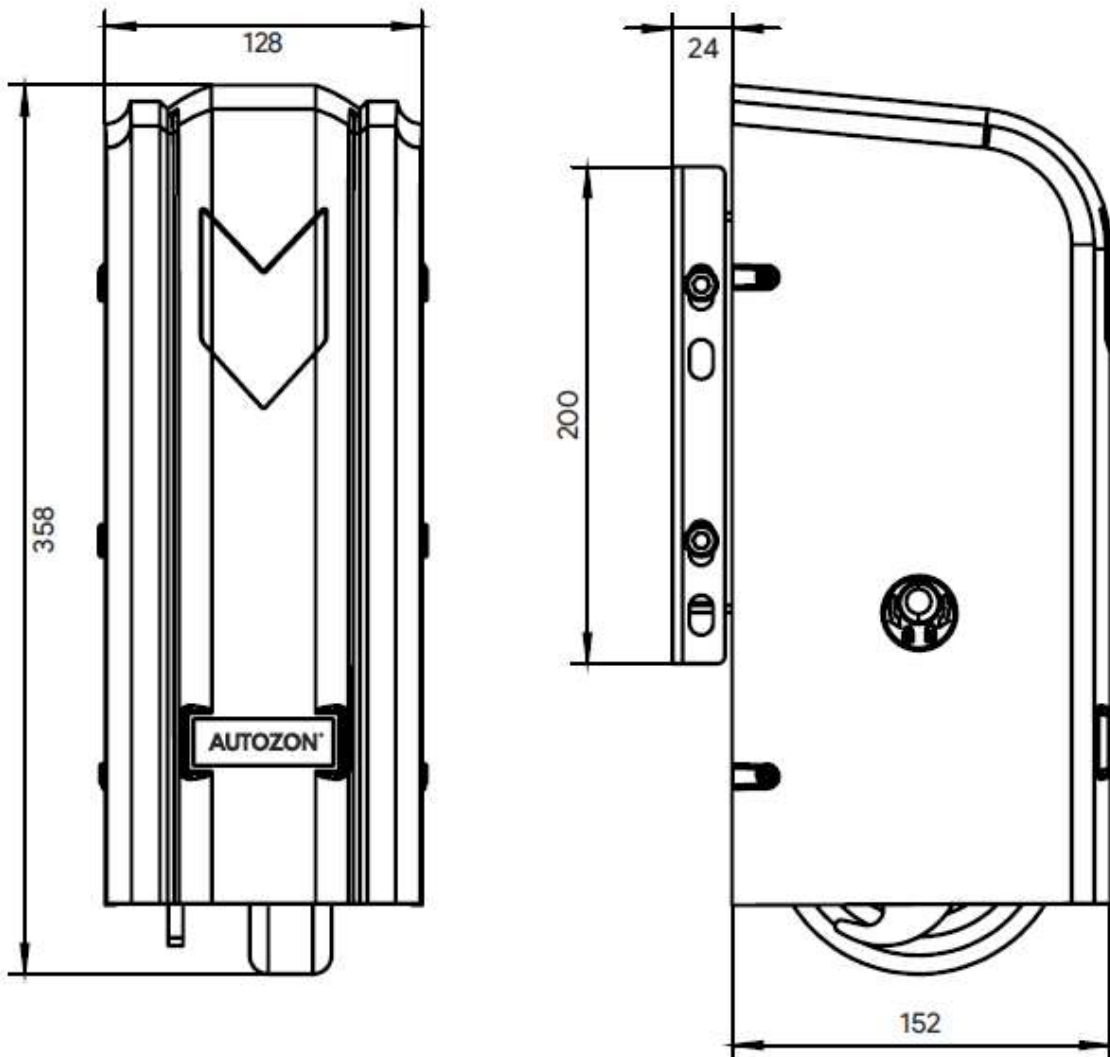

CONTROL AND POWER DISTRIBUTION STRUCTURE

Remark:

1. Gate opener
2. Control panel
3. Left door: $2 \times \geq 2.0\text{mm}^2$ connection wire
4. Right door: $2 \times \geq 2.0\text{mm}^2$ connection wire
5. Multi-standard copper wire (white RVV wire)
3. Classification of gate opener: Inward gate opener and outward gate opener.
4. Classification of Control system: 2- channel 5- line ordinary control system and 2- channel line wisdom control system.

Main Technical Parameters

Model	ECO - AZSW108A 400	ECO - AZSW108B 800
Power Supply	220 V - 240 V AC	220 V - 240 V AC
Motor Watt	40 W * 2 no's	65 W * 2 no's
Motor Power	24 V DC	24 V DC
Push Force	600 N	600 N
Motor RPM	52 RPM	52 RPM
Speed	15 m / min	15 m / min
Remote Distance	≤ 50 m	≤ 50 m
Environment Temperature	$-35^\circ\text{C} \sim + 65^\circ\text{C}$	$-35^\circ\text{C} \sim + 65^\circ\text{C}$
Package Weight	19.5 Kg	20.5 Kg

Function Characteristics

1. Single-leaf or double-leaf opening: This function can be activated by pressing button.
2. Control box locking: To avoid unauthorized opening, this function can be activated by remote control.
3. Infrared detection and protection: The gate will automatically re-opened if any passing vehicle or person is detected during closing
4. Automatic detection and access control: The gate opener can be connected to card reader, fingerprint scanner, anti-theft alarm, camera or any other devices for automatic access control.

Please refer to the Instructions Manual of the control box for the foregoing functions, interfaces and detailed operating and setting methods.

Operating Methods

This gate opener can be controlled electrically and manually. Please remove any obstructions within the working scope of the gate body and no vehicle or person allowed access during operation.

(I) Electric control operation

1. Press the button of the control box to realize automatic gate opening, closing or stop.
2. Press the button of the remote control to realize automatic gate opening, closing or stop.
3. The gate access control system can identify and control access automatically.

(II) Manual control operation

1. Manual opening: insert the clutch key into the lock hole and rotate it clockwise to disengage the clutch (the gate opener in manual mode) , then push the gate open by hand.
2. Manual closing: push the gate to near the close position when it is in manual mode, insert the clutch key into the lock hole and rotate it anticlockwise to engage the clutch(the gate opener now in electric mode),then push the gate to the lock position by hand.

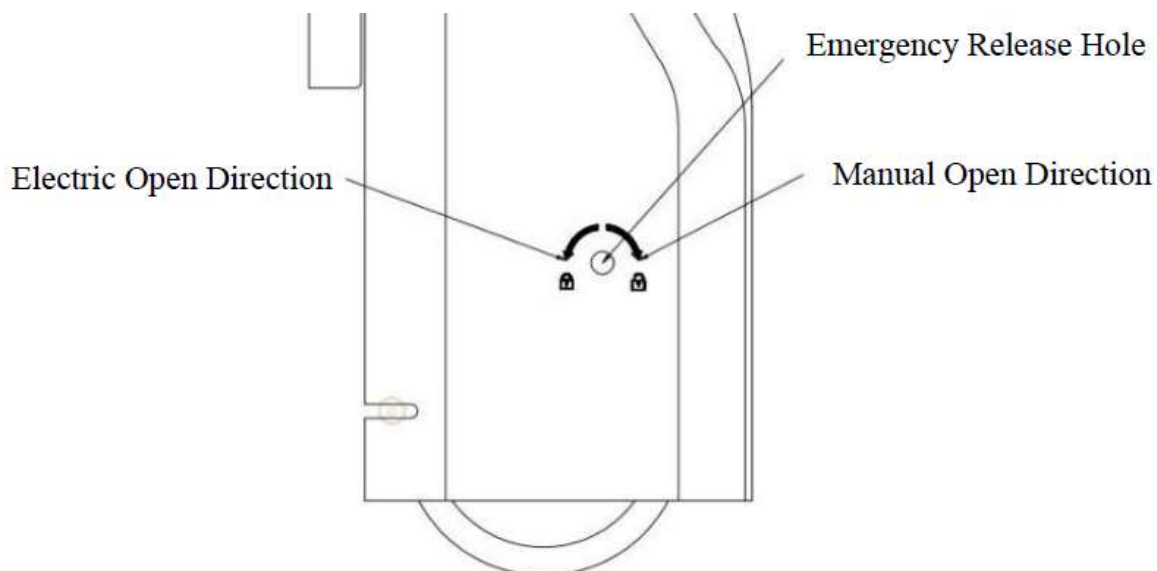

Installation Methods & Debugging

Preparation

1. Check the flexibility of the gate during opening and closing; make sure that the gate does not bounce back when the gate reaches the open or close limit position. When the gate is in the close position, the bottom edge of the gate frame shall be at least 25mm above the ground (slightly higher than the stop iron). Make special adjustments if the gap is less than 25mm.

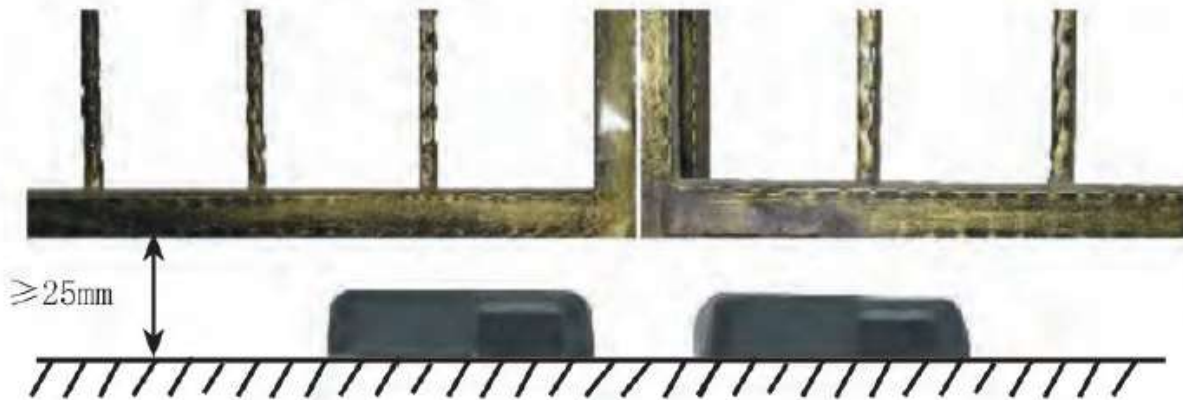

2. The unevenness of the ground within the working scope of the gate opener. Fall h = Height of the highest point of the ground - height of the lowest point of the ground.

- When $0 < h \leq 80\text{mm}$, the fall is normal, choose the standard configuration.
- When $80\text{mm} < h \leq 140\text{mm}$, the fall is large, choose long configuration.
- When $140\text{mm} < h \leq 300\text{mm}$, the fall is too large, choose special configuration (dual slide)

3. Determination power of the gate opener Measure the width, height, weight of the gate leaf and determine if ordinary or high-duty motor shall be chose according to the sealing conditions and external environments

4. Choose the model and configuration of the gate opener according to the user type and functional requirements.

5. Bury the wire pipes with reference to the wiring diagram of the power distribution system of the gate opener and determine the diameter and number of cores of multi-strand flexible wires(power cables).Two ways of system configuration are available according to the connection ways of gate opener and control box:

a) 2-channel 2-line gate opener and control box the gate opener and the control box are connected via two circuits of two-core power cables.

b) 2- channel 5-line gate opener and control box the gate opener and the control box are connected via two circuits of five-core power cables.

If any electric lock is added, please adopt two-core power cables to connect the electric lock to the control box.

If any infrared sensor is added, please adopt three-core power cables to connect infrared sensor to the control box, and use two-core power cables to connect the infrared sensor transmitting terminal with receiving terminal.

If any card reader is added, please adopt four-core power cables to connect the card reader to the control box.

Cautions:

a) The wire pipes buried right below the projection of the gate at the close position shall not conflict with the stop iron to be mounted.

b) In order to minimize circuit losses, the connecting wires (or power cables) of the gate opener shall have a sectional area above 1 square mm, while other signal wires shall have a sectional area of about 0.5 square mm.

6. Ensure that an inward gate opener is adopting for an inwardly-opening gate, while an outward gate opener shall be adopted for an outwardly-opening gate.

(II) Installation of control box

1. Please install the control box (indoors or outdoors) according to relevant electrical safety code.

2. Install the control box as close to the gate as possible in order to shorten the wires, reduce circuit losses and save electricity.

3. An independent external power switch, leakage protector or over-current circuit breaker shall be installed.

4. If any external packing box is to be installed, the shielding effects of metal products to remote signals shall be considered and the antenna shall be stretched out of the packing box.

5. The control box shall be installed in an appropriate position and the height and environment shall be well ventilated. Measures shall be taken to avoid rainfalls, sunshine or child access.

6. The wiring method: please refer to the Instructions Manual of the control box.

(III) Installation of gate opener (the pair of gate openers shall be of the same specifications)

1. Determine the installation position of the gate opener: mark the installing positions of the two gate openers on the gate body when the two gate leaves are closed.

Noted: The distance of the inner edges (outer covers) of both gate openers shall not be less than 70mm for the purpose of convenient manual operation.

2. There are two methods to determine the installing heights of the mounting plate: Firstly push the gate to the lowest position of the travelling area.

- a) Method 1: move the mounting plate up and down until the bottom edge of the mounting plate is 130 to 120 mm above the lowest point of the ground. Mark the installing height of the mounting plate.
- b) Method 2: keep the gate opener in nature state (the spring is neither compressed nor extended) and against the gate body vertically. Mark the position of the mounting plate on the gate body. Move the mounting plate further downward by 10-20mm from the mark; this is the actual installing height of the mounting plate.

In either method, the installing height of the mounting plate shall be appropriately adjusted according to the ground smoothness, gate size and weight, hinge flexibility and other factors.

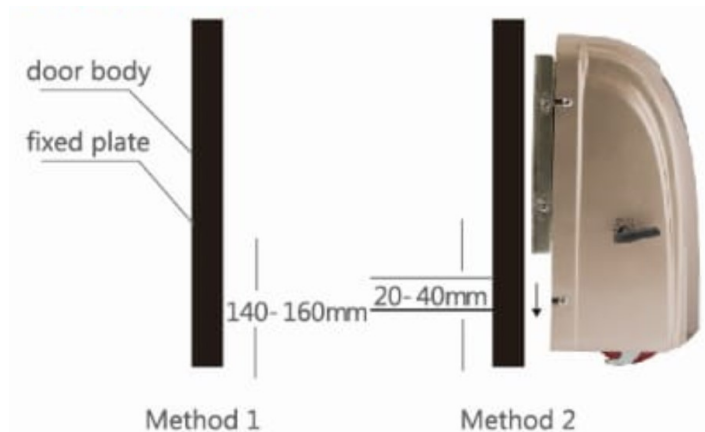

Note:

1. Fasten the mounting plate with four bolts before mounting plate installation.
2. Keep the mounting plate vertical during installation and bolt or weld it onto the gate body.
3. Make one hole on either of the inner sides of the gate on the bottom frame (for entry and exit of wires) for wires. One flexible sleeve cover the wires shall be used where they go through the holes.

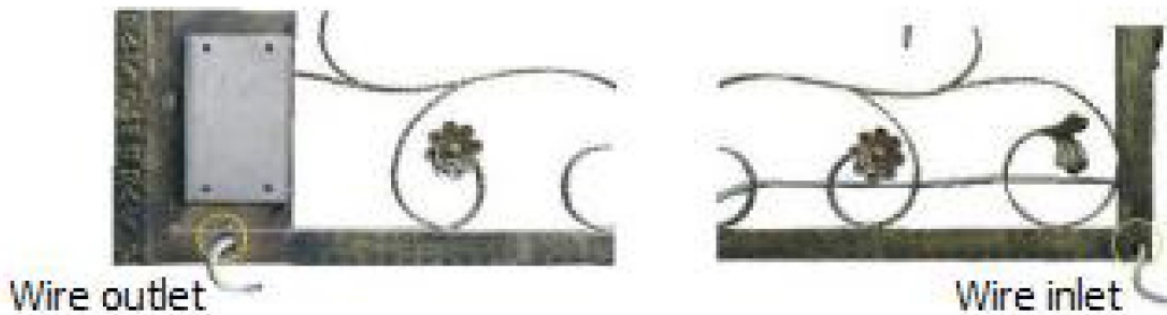

4. Fix the gate opener and connect the wires (whose color shall be the same as label of terminal block of the control box or the color of the plug wire).

Check: Use the key to switch the gate opener to manual mode and push the gate body forward and backward.

The gate opener shall rise and fall freely with the fluctuation of the ground and no dead locking, hanging and suspending etc.

5. Installation of the stop iron (please refer to the following points):

When the gate is in the mode of manual operation, move the gate to the close position and install the stop iron into the lock hook. Use the key to switch the gate opener to electric mode and lock it there. Move the stop iron so that the centerline of the lock hole is aligned to the lock hook and mark the position of the stop iron. Drill a hole on the ground and fasten the stop iron with expansion bolts.

Position of stop iron and gate

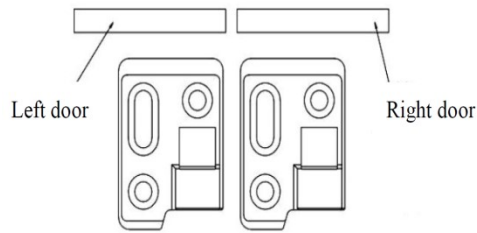

Position of stop iron and lock

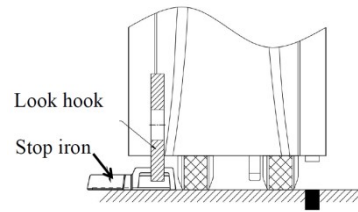

Note	a) The stop iron for the gate leaf that is firstly closed shall be installed first when the gate has a floor stop. The two stop irons shall be distanced from each other by 10-15mm.
	b) The ground where the wheels of the gate opener are rested and the ground where the stop irons are rested shall be on the same level when the gate is at the close position.
	c) If any rubber buffer is to be installed between the pressure plates of the two leaves, they should be installed before the gate opener is installed. Otherwise, the reliable locking of the gate opener may be affected and the proper operation of the gate opener may even be disabled.
	d) The stop irons should be installed firmly and they shall not become loosened or displaced in operation.

Manually open and close the gate to check if the stop irons are properly installed.

A. Push the gate towards the stop iron when the gate is in manual mode, then use the key to switch it to electrical mode. Push the gate forward and the gate shall be reliably locked.

B. Use the key to switch the gate opener back to manual mode and the gate can be easily pushed open.

Installation of Limit Magnet For Opening

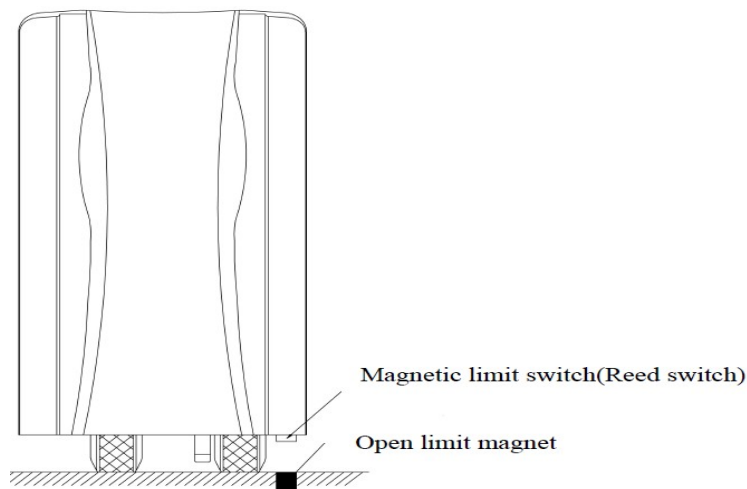

Open the gate to maximum or designed position and retreat it by 200mm. Find the ground projection of the magnetic switch at the bottom of the gate opener, drill a hole there ($\varnothing 22\text{mm}$) and bury a magnet leveled with the surface.

Fixing Plate Installation Instructions:

1. Push the door (installed with the motor) to open limit, and put the fixing plate on this position

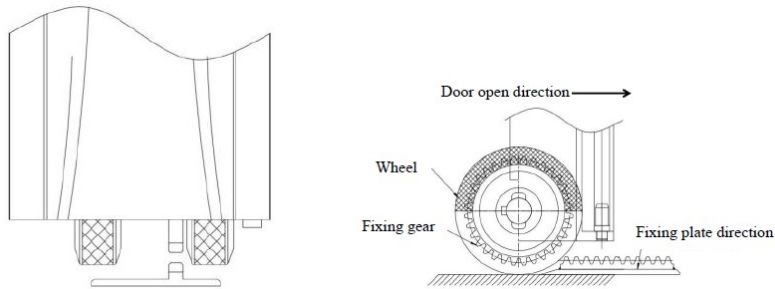

2. Draw the center line of the wheel on the ground.
3. Switch the motor to manual mode and push the motor away from the center line which has been drawn (close direction), and then make center line of the rack on the fixing plate shifted to the drawn center line and aligned with fixing gear
4. Push the door to the fixing plate and to open limit manually, and check if the door open completely.

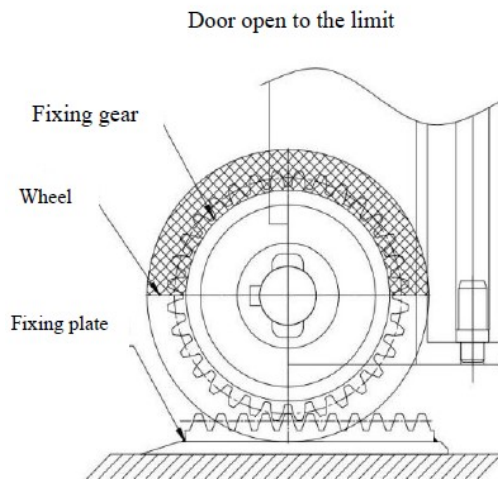

5. Push the door away from fixing plate manually and then fixing the plate.
(Specific steps refer to the installation of stop iron)

(IV) Operation and debugging of the electric gate opener

Check if the wiring is properly done and if the voltage meets the requirements before operation.

Use the key to disengage or engage the clutch and check if the gate can be properly manually opened and closed. Push the gate to the mid-position and engage the clutch of the gate opener (in electric state). Switch on the mains power and the indicators are in normal condition.

1. Press the button of the remote control or the control box to open, stop and close the gate .Observe if the gate opener works in a stable and consistent manner and if it automatically stops in an accurate manner when the required position is reached. Otherwise, check it relevant parts are properly installed.

2. Check if the gate moves in the right direction as displayed by the control key. Otherwise, please correct wiring of the gate opener or motor.

3. Please see the control box's Instructions Manual for the locking method of keys.

4. Debugging of automatic stop upon obstacle and motor's loading capacity: it is necessary to appropriately adjust the potentiometer (pressure or resistance) of the control box according to the gate size, hinge flexibility and ground evenness in order to increase or decrease the motor's capacity against resistances.

5. Test methods of automatic stop upon obstacle during opening, and re-open upon obstacle

During Closing:

a) Apply a counterforce (push or pull with hands) on one leaf during opening and the gate shall stop opening.

b) Apply a counterforce on one leaf during closing and both leaves shall retreat in the opening direction. If the motor's capacity against resistance is set to be too small the motor may easily stop operation. If it is set to be too big, the protective effects may be reduced.

6. Please read the control box's Instruction Manual for the protection time of the gate during operation. If the protection time is setting too short, the gate will stop automatically before it reaches the desired position.

7. Please read the control box's Instruction Manual for setting and time adjustment for automatic gate closing.

8. The time difference for delayed closing of the gate leaves shall be adjusted according to the different degrees of opening of both leaves.
9. Please see the Instruction Manual for details about the card reader, infrared protector and wiring.

Control Board Function:

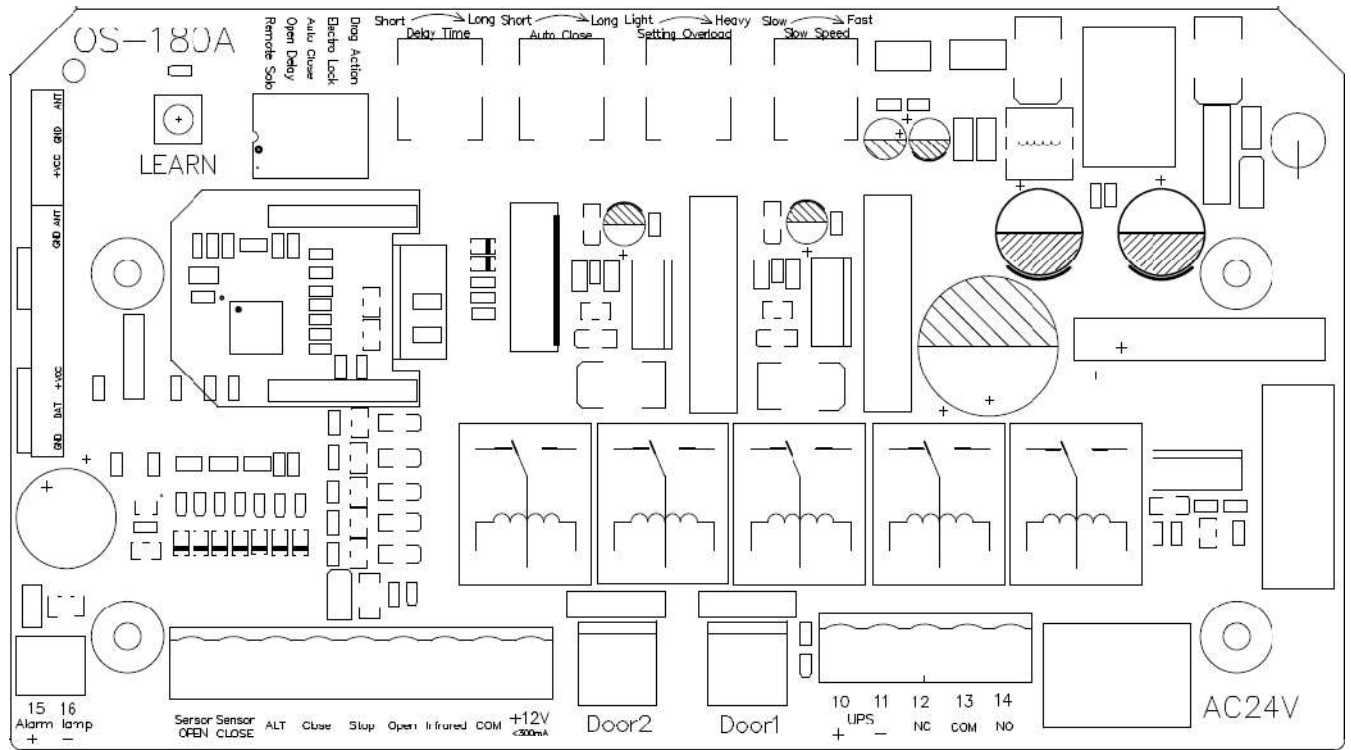

Error Code

- E-03 Infrared signal trigger**
- E-02 Door blocked**
- E-01 Running Timeout**

Control Instructions:

1. Key-Learning Key

1. Short press, the buzzer beeps a short while, the LED is always on, and enters the remote control learning state: at this time, press any button of the ballad control, the buzzer beeps 2 short times, the LED flashes, the learning is successful and exits the learning state
2. Press and hold for about 10s until the buzzer sounds for a long time and the LED flashes to clear all remote controls

2. DIP Switch

DIP - 1. Remote control single: ON -- Only the button pressed during remote learning is valid, and other buttons are invalid. When the button is pressed, the function is switch off. OFF--The remote control button corresponds to the corresponding function of the button operation. Close, open, single, open, stop.

DIP - 2. Open the door first: ON-- the time to open the door first is 3s OFF -- the time to open the door first is 1s

DIP - 3. Automatic closing: ON-after the door is fully opened, wait for the automatic door-closing delay to arrive, and then automatically close the door
OFF--stop after the door is fully opened

DIP - 4. Electric control lock: ON--The function of the electric control lock is turned on, and the signal 1s of the electric control lock is connected before opening the door (select normally open or normally closed through the interface) OFF--The electric lock function is turned off.

DIP - 5. Reverse when encountering resistance: ON-When the door encounters resistance during opening and closing, the door will be automatically closed when the door is opened. Stop when the door is closed. OFF--When the door is blocked during the opening and closing process, the motor will be stopped

3. Potentiometer

1. Door closing sequence Delay Time: the time interval between closing the door first and then closing the door: 0-120 seconds

2. Auto Close: When auto close is ON, after the door is fully opened, wait for the automatic close time interval: 0-120 seconds

3. Power adjustment Setting Overload: resistance adjustment (default

maximum), can be adjusted according to actual needs

4. Slow Speed: Slow running speed ratio: 30%-100%

Control Panel Function and Interface Control Description

Function introduction:

- Real-time monitoring, stop when encountering sun or blockage, rebound, and motor running time protection, etc.
- Using DC motor, and real-time monitoring of motor running status, line protection, safer and more reliable
- With slow start, early deceleration switch door to limit, soft stop function
- Sufficient interfaces and adjustable parameters are reserved for different usage scenarios: such as cloudy force, closing time, etc.
- With one-button remote control, one remote control can control multiple doors, easy to carry
- Automatic door closing function, used with external access control recognizer to realize automatic door opening and closing
- It has compatible control interfaces such as single-key cycle control, independent switch stop control interface, infrared resistance detection, and ground sensing detection.
- Support Bluetooth module, support We Chat applet, and use mobile phone to control the door operator
- External electric lock control can be connected, which is safer when the door is closed
- It can provide 12V DC power supply externally, and the maximum supply current can reach 1A, reducing the wiring of extended controls.

Interface Description:

1. EXTERNAL WIRING PORT

1. Ground sense OPEN: Double ground sense to close the door, you need to trigger two ground sense signals to close the door (ground sense in front of the door)

2. Ground sense CLOSE: Double ground sense to close the door, need to trigger two ground sense signals to close the door (ground sense behind the door)

3. Single key: external key control interface, the control mode is open, stop, close, stop cycle

4. Close the door: close the door control interface

- 5. Stop:** stop control interface
- 6. Open the door:** open the door control interface
- 7. Infrared:** sensor signal interface (infrared sensor: 12V power supply, normally open signal)
- 8. Public:** common terminal of control interface, negative pole (GND)
- 9. +12V:** 12V output positive pole, maximum output current: 1A

Note: If you need to close the door with a single ground sense, just short the ground sense OPEN and ground sense CLOSE and connect it to the ground sense trigger signal

2. Motor Interface

- 1. Gate Opener 2: Swing Gate DC motor 2 interfaces
- 2. Gate Opener1: Swing Gate DC motor 1 interface

3. UPS and Electric Control Lock Wiring Port

- 1. UPS +:** UPS battery positive connector
- 2. UPS-:** UPS battery negative connector
- 3. NC:** Electronic control pin normally closed signal interface
- 4. COM:** Electric lock signal common terminal
- 5. NO:** Electronic lock normally open signal interface

4. Power Input Port

24VAC input: Transformer 24V output interface

5. Control Panel Interface

- 1. External panel control button board, corresponding to single-button control and remote learning two buttons and 4-digit digital tube display status
- 2. Digital tube display: open (on).close (off).stop (stop), remote control learning and number: L000 (number of remote control)
- 3. The learning function of panel rhyme control is as follows: long press the learning remote control button on the panel until the digital tube display changes to lxxx, then release the button to enter remote control learning. You need to press the learned remote control for guidance before you can add a new remote control. This button only supports remote adding, not remote clearing. If remote control is required, please use the learning key on the main board to operate.

Maintenance and Services

1. The turning parts of the gate opener shall be kept clean and free of any attachments.
2. Frequently clean away the debris in the grooves of the stop iron.
3. Properly lubricate various mechanical moving parts very quarter.
4. Check the power protector and the performance conditions of the backup storage battery

Trouble Shooting

Faults	Possible reason	Removal method
Door not move when press the remote control	<ol style="list-style-type: none"> 1.Check if clutch is in electric state 2.Power outage 3.Fuse wire burn 4.Remote controller invalid 5.Circuit broken 6.Control box or door machine broken 	Recover Recover power supply Replace Check and replace Check and maintain Maintain
Short remote control distance or remote controller invalid	<ol style="list-style-type: none"> 1.Low battery 2..Control box locked or damage 3.Same frequency interference 4.The receive module of control box damage 	Replace Unlock or replace Wait for the elimination of inference source Replace the receive module of control box
Fail to stop when travel to the limit	<ol style="list-style-type: none"> 1.The magnetic steel missing 2.Open limit switch or components invalid 	Recovery Maintain, replace
Fail to stop or re-open when travel to the limit	<ol style="list-style-type: none"> 1.Close limit switch invalid or spring damage 2.Locating iron loose or barriers 3Sequence error of open and close 4.Circuit faults 	Replace Maintain Re-travel Maintain
Door not move when press OPEN, CLOSE	<ol style="list-style-type: none"> 1.The blocking protection of motor travel (the set value is small) 2.Limit components, limit switches or circuit board of control box faults 	Check hinge or add lubricant on lifter door opener. Maintain, replace
Press OPEN , CLOSE, the indicator light flashes but the door opener can not move.	<ol style="list-style-type: none"> 1.Circuit short or unwell connected 1.Fastening pieces loose or damage 3.Motor damage 	Maintain Maintain, replace Maintain, replace