

PAT 6

Swaraj's Patriot Series Barriers are the ideal choice for heavy duty operation. When the requirement is a combination of maintenance free operation and aesthetic looks, Patriot barriers fit in perfectly. Made indigenously, the Patriot Barriers have the following features:

FEATURES & BENEFITS

100% DUTY CYCLE OPERATION WITH 5 MILLION MTBF

Maintenance-free torque motor ensures 100% duty cycle operation with 5 million MTBF. The heavy duty Gear Drive Motor is environment friendly, energy-saving, and maintenance-free. There is no electric shock or overheating while working continuously, which protects the controller and prolongs its lifetime.

EASY INSTALLATION AND MAINTENANCE REDUCES YOUR LABOUR COST

Simple structure and double limit switch design ensures easy installation and maintenance and also reduces maintenance cost.

MANUAL OPTION IN CASE OF POWER FAILURE

If power is suddenly switched off while the boom is closing, the barrier is equipped with a manual knob which enables the operator to manually open or close the barrier.

HEAVY-DUTY, WEATHER-PROOF AND SIMPLE-DESIGN HOUSING

The housing adopts 2mm precise machining cold-rolled plate and static electricity sprayed anti-UV surface which does not fade over time in. It confirms to IP68 dustproof and waterproof standards. It is simple in design and aesthetically decorates your premises. Full Stainless Steel Body is available on requirement.

SINE LEVER DRIVE MECHANISM ENSURES SMOOTH LANDING OF BOOM WITHOUT SHAKING

The patent pending precise casting sine lever drive mechanism enables the boom arm to move from slow to fast when it starts, and fast to slow when it stops. This effectively reduces the shaking of the boom arm and reduces the burden of the electrical motor. In this way the lifetime of the motor and mechanical components are prolonged.



SPECIFICATIONS

MODEL NO.	PAT 6
DUTY CYCLE	100 %
POWER	AC 220-230V, 50/60HZ
POWER CONSUMPTION	120 W
OPENING/CLOSING SPEED	3 TO 4 SECONDS
MAXIMUM BOOM LENGTH	UP TO 6 METERS
HOUSING	MILD STEEL WITH ZINC COATING (INSIDE & OUTSIDE) PLUS ANTI-CORROSION TREATMENT (SS HOUSING ALSO AVAILABLE)
HOUSING DIMENSION	350mm×275mm×1110mm
HOUSING BASE FRAME	MILD STEEL
OPERATIVE OPTIONS	REMOTE CONTROL & PUSH BUTTON
IN CASE OF POWER FAILURE	OPEN/CLOSE OPTION WITH MECHANICAL HANDLE
IP RATING	COMPLIANT TO IP68 STANDARDS
SAFETY FEATURES (OPTIONAL)	WARNING/ TRAFFIC LIGHTS, PHOTOCCELL EYE FOR HUMAN SAFETY, LOOP DETECTOR FOR VEHICULAR SAFETY
OPERATING TEMPERATURE	-25 DEGREE CELSIUS TO +60 DEGREE CELSIUS
HUMIDITY	5%-95%
MTBF	5 MILLION OPERATIONS

Detection of Post Intrusion (Optional)

The boom barrier is fitted with a special sensor, which is capable of detecting a forced intrusion and transmitting the same to the operator which can further be integrated with bollards/tyre-killers/ road blockers.

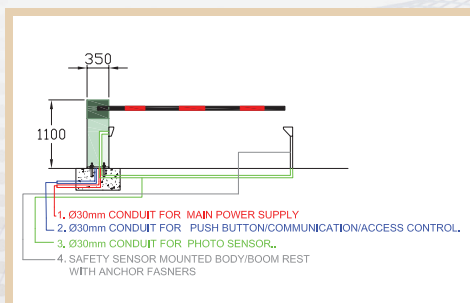

Civil Provisions

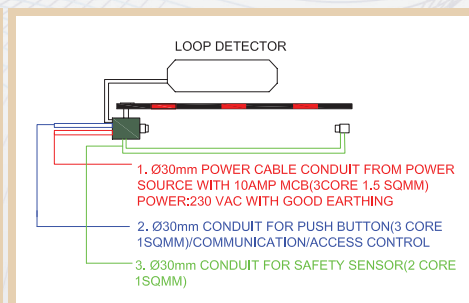

Electrical Provisions

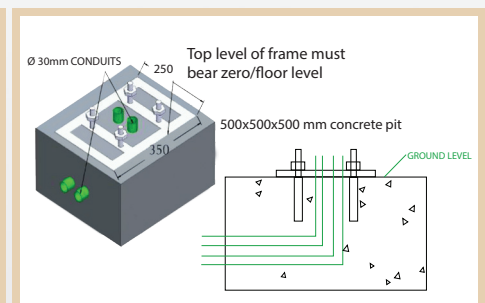

Foundation Frame

“PROUDLY MADE IN INDIA”